

Analog Frontend for Fringe Field Capacitive Soil Moisture Sensor

Manash Protim Goswami¹ and Utpal Sarma²

^{1,2}Dept. of Instrumentation & USIC Gauhati University
E-mail: ¹manash_999@rediffmail.com, ²utpalsarma@gauhati.ac.in

Abstract—For in-situ soil moisture measurement, commonly applicable for the agricultural, geotechnical, environmental applications, a suitable, low cost and efficient analog frontend for a capacitive soil moisture sensor is developed and presented in this work. There are various sensors commercially available for soil moisture measurement for laboratory and as well as in-situ measurement. A capacitive soil moisture sensor based on fringe field effect has been developed and design consideration of its signal condition is presented. The capacitance of the sensor is converted to voltage using an impedance bridge circuit developed for this purpose. The bridge output is conditioned with two peak detectors and a subtractor. The d.c. output voltage is monitored by a $6\frac{1}{2}$ digit digital multimeter(DMM) 34401A of Keysight(Agilent) Technologies and logged as microsoft excel file in the computer by general purpose interface bus(GPIB) interfacing. The developed system has been gone through various testing with different soil samples for different moisture contents and experimental results are shown. The characterisation of the conditioning circuit is also discussed.

1. INTRODUCTION

Capacitive sensor are widely used for various applications like flow measurement [1], level measurement [2,3], proximity detection [4], measurement of humidity [5], position sensing [6] etc. Fringe field capacitor was designed for various applications like chemical level detection [7], water level detection [3], soil moisture measurement [8]. A. M. Thomas measured the fringe capacitor of a designed probe with coplanar electrodes operated at VHF Range [9]. H. Eller and A. Denoth designed a fork-like geometry capacitor sensor and measured the impedance with a twin T-bridge for natural soils [10]. They did a comparative study with thermo-gravimetric method and time domain reflectometry and found a satisfactory result. Apart from them, Bell et al. designed an annular electrode and Ungar et al. developed a cylindrical shaped probe for impedance measurement [11, 12]. Fringe field capacitor is the widely used sensor and realization of the fringe field capacitor using printed circuit board giving a pattern of inter-penetrating comb pattern is the cost effective and easy to install in in-situ measurement.

Various techniques are presented and used for capacitance measurement. It includes charge discharge method [13],

bridge based method [14], capacitance to digital conversion method [15,16], direct micro-controller interfacing method[3] etc. Some capacitive sensor have a parallel resistance which can even go below 1 MΩ [17]. For such type sensors, impedance measurement is the most suitable applicable method. An impedance bridge based signal conditioning method suitable for such types capacitive sensor is presented in this paper. This method is also applicable for in-situ measurement because of small circuitry, low frequency application which will also make the device low power consumption. Experimental results for different soil moisture content are presented and analysed.

2. SENSOR DESIGN

Capacitive sensor converts a change in position or properties of dielectric materials into an electrical signal. Area of the capacitive plates, distance between the plates and the dielectric constant are three parameters through which a capacitive sensor can be realized.

$$C = f[d, A, \epsilon_r] \dots\dots\dots 1$$

Where d is the distance between the plates, A is the area of the capacitive plate and ϵ_r is the dielectric constant. Fringe field capacitor is a capacitor having multiple capacitive plates arranged in inter-penetrating comb pattern. Capacitance of the sensor having n capacitive plates is

$$C = \epsilon_0 \epsilon_r A(n-1)/d \dots\dots\dots 2$$

The pictorial view and specifications of the designed sensor is shown in the Fig. 1.

PCB technology is a very excellent technology to realize interpenetrating comb pattern. An interpenetrating comb pattern electrode is designed in printed circuit board as traces to give a fringe capacitance. Here, sensor is fabricated in such a way that copper (Cu) are kept on the upper side of the FR4 board in a shaped like inter penetrating combs. It gives a fringe capacitance. Total no of capacitive plates are 51 out of which 26 plates are connected in one side and 25 plates are connected in the either side. The separation of two plates is 0.70 mm, the width of one plate is 1.20 mm and the total

length of the sensor is 103.25 mm, out of which sensing part is 79.4 mm. The Cu traces masked with quick drying lacquer spray (Acrylic Epoxy) of thickness 52.5 μm . The designed sensor is shown in the Fig. 2.

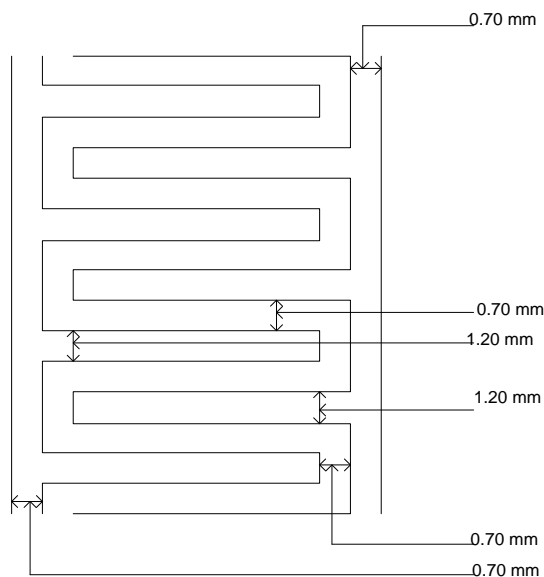

Fig. 1: Interdigitated electrode shaped sensor



Fig. 2: Designed Sensor

3. SIGNAL CONDITIONING

Fringe field capacitive sensor gives capacitance with parallel resistance. So, Impedance bridge based signal conditioning is the efficient way for measuring the sensor output[17]. Bridge is excited by a ac signal of low frequency(1KHz and 5V peak to peak). The output at the two test points (T1 at Ch 2 and T2 at Ch 1) shown in the Fig. 3 have some phase difference with amplitude difference.

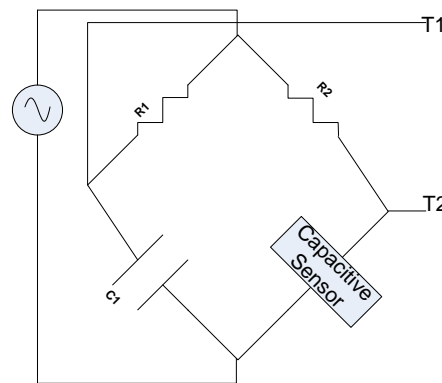

Fig. 3: Bridge circuit for impedance measurement

The output waveform at test points T1 and T2 are shown in Fig. 4 using the Digital Storage Oscilloscope(DSO) DX1103.

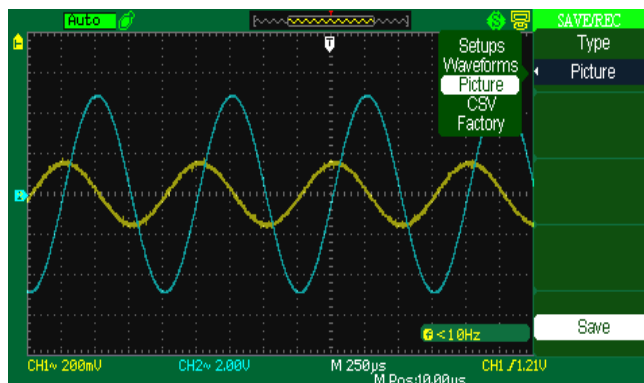

Fig. 4: Waveforms at test points T1 and T2

To sense the soil moisture with this sensor, both amplitude difference and phase difference can be used. But easiest method is the measuring the difference in amplitude. As there are some phase difference between the two signals at the test points, signals are fed to two different peak detector circuit. The schematic of basic peak detector circuit is drawn in Fig. 5.

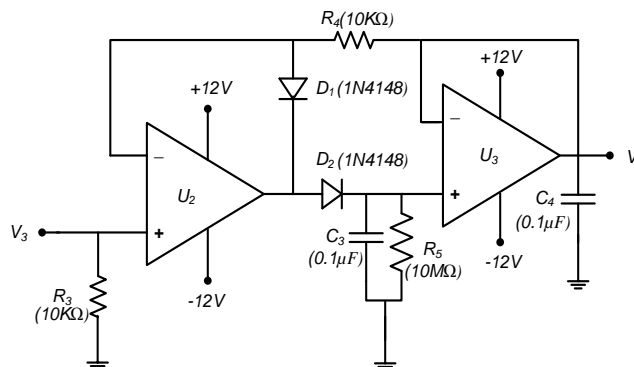

Fig. 5: Peak Detector circuit

The dc output of the peak detector is shown in the Fig. 6.

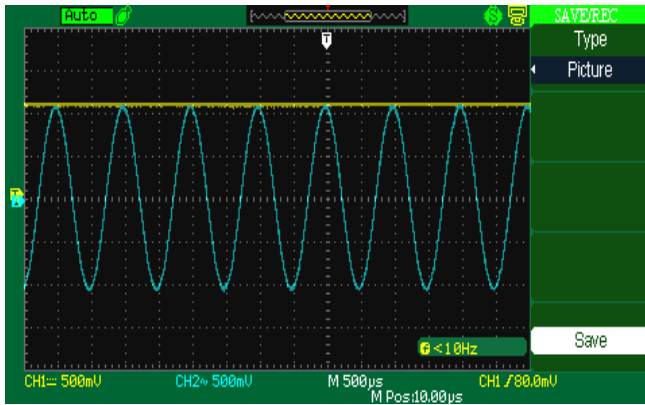

Fig. 6: Peak detector output

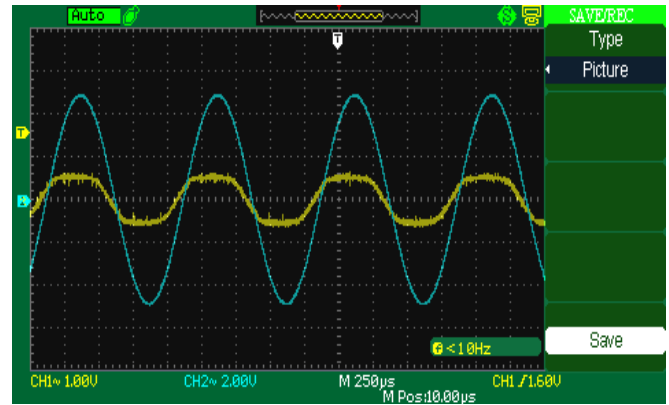

Fig. 7.a: Waveform when the sensor is emerged in soil

The dc voltages of the two peak detectors are used in the inputs of a subtractor and the difference is measured by the DMM.

4. EXPERIMENTAL SETUP

Arrangement as shown in the Fig. 3 has been done for the experiment. The soil sample prepared as per the standard D4959-00 of American Society for Testing and Materials (ASTM) International is kept in a desiccator to prevent the vaporization [18]. Designed sensor is inserted into 9 cm depth of the soil sample. The capacitance output of the sensor is measured by S-928 Systronics auto LCR-Q tester. To measure the sensor response, the sensor is connected to the signal conditioning circuit and the voltage output is measured by a 6 1/2 digit digital multimeter 34401A.

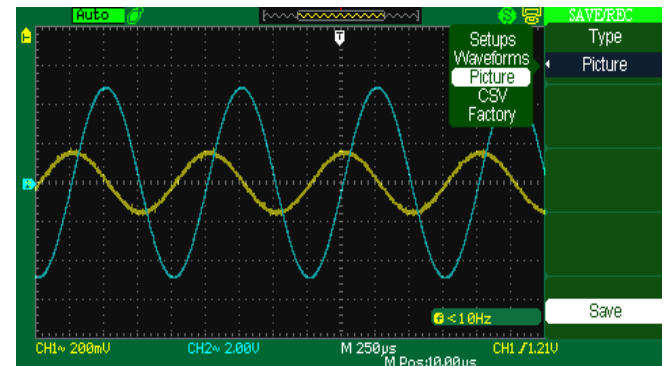

Fig. 7. b: Waveform when the sensor is fully emerged in water



Fig. 6: Laboratory setup for measurement of the soil moisture

5. RESULTS AND DISCUSSIONS

The designed sensor is inserted in soil sample kept in the desiccators and also fully emerged in water and the bridge outputs at test points T1 at channel 2 and T2 at channel 1 are shown in the Fig. 7.a and Fig. 7.b respectively for the excitation signal of 5V Peak to Peak and 1 KHz frequency.

After signal conditioning the voltage output was measured by a 6 1/2 digit digital multimeter for different moisture levels of the soil sample. The soil sample is kept in a desiccator to prevent vaporization. After adding water, the soil sample is thoroughly mixed to get uniform distribution of the water. Then the sensor is inserted into 9cm depth in the sample and desiccator is closed using silicon grease.

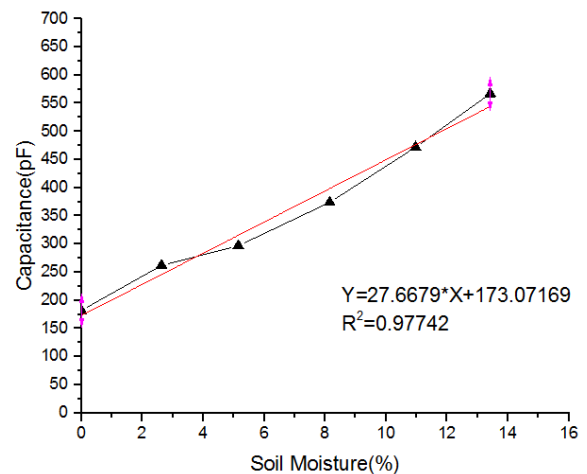

Fig. 8: Sensor output (capacitance) with change in soil moisture

After keeping 1 hour to settle the water, the weight of the container is measured by a weighting machine with accuracy 0.01 gm. The soil moisture of the water adding sample is now calculated by the gravimetric method [18]. The sensor output for various moisture content of the sample is shown in the Fig. 8. The sensitivity of the sensor is found 27.67 pF/% and the standard error is found as 1.876 pF. The goodness of fit is 0.9774.

The voltage output of the signal conditioning circuit changes linearly with the change in soil moisture content of the sample and predicted in the Fig. 9. The goodness of fit is found 0.994 for the curve and found the sensitivity as 58.45 mV/% change in soil moisture and the standard error is found as 1.71mV.

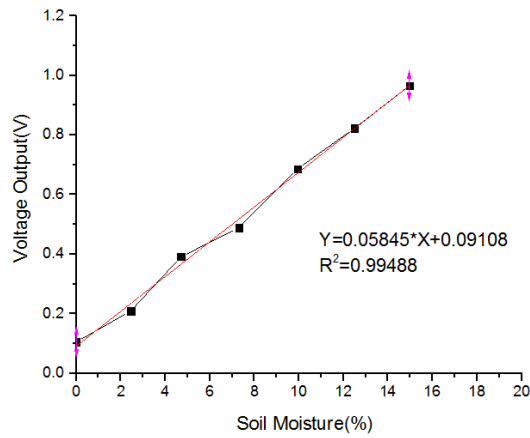

Fig. 9: Voltage output after the signal conditioned

The system was run for a duration of 13 minutes at soil moisture 8.17% and found a variation limited within 0.03 V maximum and shown in the Fig. 10.

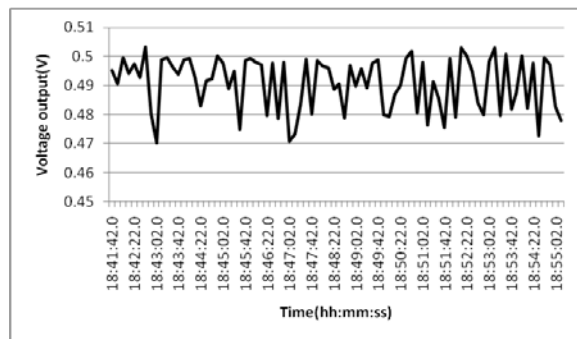

Fig. 10: Variation of the voltage output for a duration

6. CONCLUSION

Interpenetrating comb pattern fringe field capacitor is successfully realized using PCB technology and performed a series of laboratory test for the designed sensor. A impedance bridge based signal conditioning is also developed successfully for these type of capacitive sensor and output is

electrically characterised and found a maximum variation from the shown Fig. 10 is 0.03V with sensitivity 27.67pF/% change in soil moisture for the sensor and 58.45 mV/% change in soil moisture for the system.

7. ACKNOWLEDGEMENT

Department of Science and Technology, Govt. of India is acknowledged for providing INSPIRE fellowship to one of the authors. The authors of the paper acknowledge Dept. of Instrumentation & USIC, Gauhati University for providing the facility to do the work.

BIBLIOGRAPHY

- [1] Bera, S. C., and Mandal, H. "A flow measurement technique using anoncontact capacitance-type orifice transducer for a conducting liquid," *IEEE Trans. Instrum. Meas.*, vol. 61, no. 9, pp. 2553–2559, Sep. 2012.
- [2] Bera, S.C., Mandal, H., Saha, S., and Dutta, A. "Study of a modified capacitance-type level transducer for any type of liquid," *IEEE Trans. Instrum. Meas.*, vol. 63, no. 3, pp. 641–649, Mar. 2014.
- [3] Chetpattaranont, P., Tapoanoi, N., Phukpattaranont, P., Jindapetch, N. "A self calibration water level measurement using an interdigital capacitive sensor." *Sensors and Actuators A*, 209, pp 175-182, 2014.
- [4] Goeger, D., Blankertz, M., and Woern, H. "A tactile proximity sensor," *Proc. IEEE Sensors*, Kona, HI, USA, Nov. 2010, pp. 589–594.
- [5] Das, J., Dey, S., Hossain, S.M., Rittersma, Z.M.C. and Saha, H. "A hygrometer comprising a porous silicon humidity sensor with phasedetection electronics," *IEEE Sensors J.*, vol. 3, no. 4, pp. 414–420, Aug. 2003.
- [6] Gasulla, M., Li, X., Meijer, G.C.M., van der Ham, L. and Spronck, J.W. "A contactless capacitive angular-position sensor," *IEEE Sensors J.*, vol. 3, no. 5, pp. 607–614, Oct. 2003.
- [7] Syaifudin, A.R.M. *et al.*, "Measurements and performance evaluation of novel interdigital sensors for different chemicals related to food poisoning," *IEEE Sensors J.*, vol. 11, no. 11, pp. 2957–2965, Nov. 2011.
- [8] Dean, R.N. *et al.*, "A capacitive fringing field sensor design for moisture measurement based on printed circuit board technology," *IEEE transactions on instrumentation and measurement*, Vol. 61, No.4, pp 1105-1112, April 2012.
- [9] Thomas, A.M., "In situ measurement of moisture in soil and similar substances by 'fringe' capacitance," *J.Sci. Instrum.*, vol.43, 1966
- [10] Eller, H., Denoth, A. "A capacitive soil moisture sensor", *journal of Hydrology* 185, pp 137-146, 1996.
- [11] Bell, J. P., Dean, T. J., Hodnett M. G, "Soil moisture measurement by an improved capacitance technique, part II: field techniques, evaluation and calibration.", *Journal of Hydrology*, 93, 79-90, 1987
- [12] Ungar, S.G., Layman, R., Campbell, J.E., Walsh, J., and McKim, H.J., "Determination of Soil Moisture Distribution from Impedance and Gravimetric Measurements.", *Journal of Geophysical Research*, vol. 97. no. 17, pp. 18,969- 18,977, 1992

-
- [13] "HCH-1000 Series Humidity Sensor Calibration and Output Data",
Circuit Data",
http://www.digikey.com/Web%20Export/Supplier%20Content/HoneywellSC_480/PDF/HCH_draft3%20Rev%2010%2021%2008.pdf?redirected=1
- [14] Amira, H., Hfaiedh, M., and Valentin, M. "Quasi-balanced bridge method for the measurements of the impedances," *IET Sci., Environ. Technol.*, vol. 3, no. 6, pp. 403–409, Nov. 2009.
- [15] George, B. and Kumar, V.J., "Analysis of the switched-capacitor dualslope capacitance-to-digital converter," *IEEE Trans. Instrum. Meas.*, vol. 59, no. 5, pp. 997–1006, May 2010.
- [16] Vooka, p., George, B. "An improved capacitance to digital converter for leaky capacitive sensors.", *IEEE Sensors journal*, Vol.15, no.11, November 2015, pp 6238-6247.
- [17] A. Heidary and G. C. M. Meijer, "An integrated interface for leaky capacitive sensor with emphasize on humidity sensor," in *Proc. IEEE IMTC*, Victoria, BC, Canada, May 2008, pp. 1613–1616.
- [18] "Quality control of soil compaction using ASTM standards",[www.astm.org>MNL>MNL70_foreword](http://www.astm.org/MNL/MNL70_foreword).